

GRAPHING LINEAR FUNCTIONS

Given: _____

a. Find the x-intercept

b. Find the y-intercept

c. Find 2 other solutions

x	y
	0
0	

d. Graph

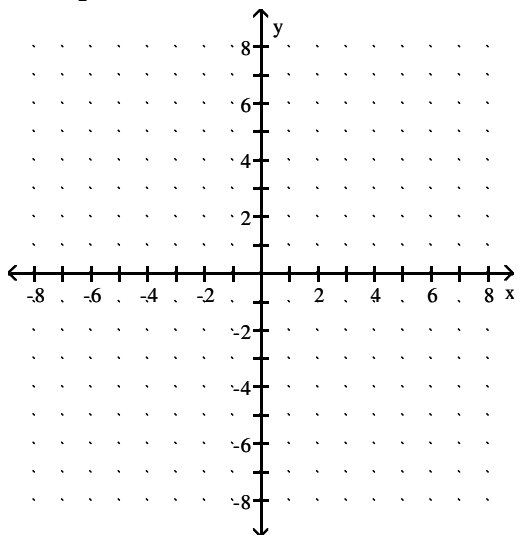

Given: _____

a. Find the x-intercept

b. Find the y-intercept

c. Find 2 other solutions

x	y
	0
0	

d. Graph

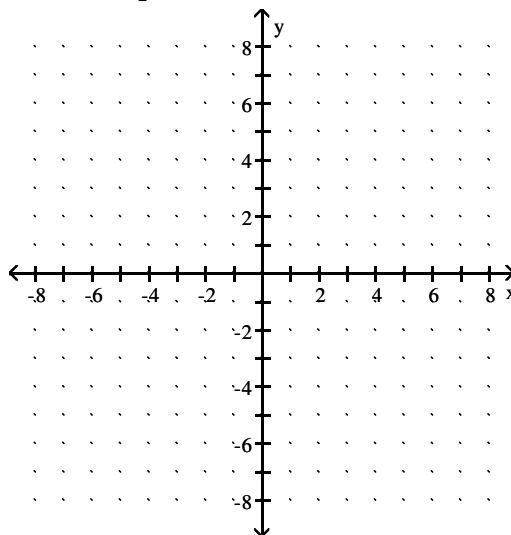

Given: _____

a. Find the x-intercept

b. Find the y-intercept

c. Find 2 other solutions

x	y
	0
0	

d. Graph

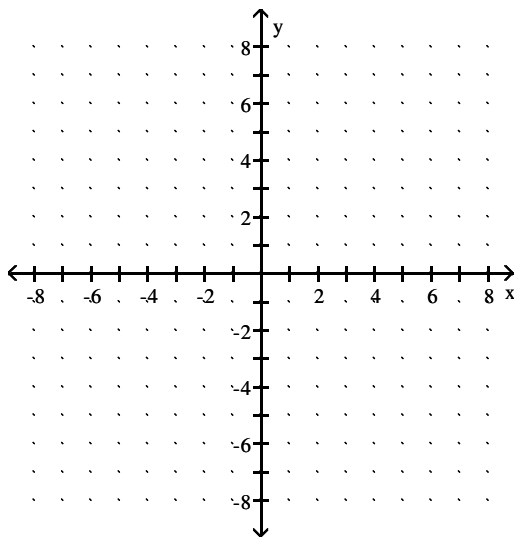

Given: _____

a. Find the x-intercept

b. Find the y-intercept

c. Find 2 other solutions

x	y
	0
0	

d. Graph

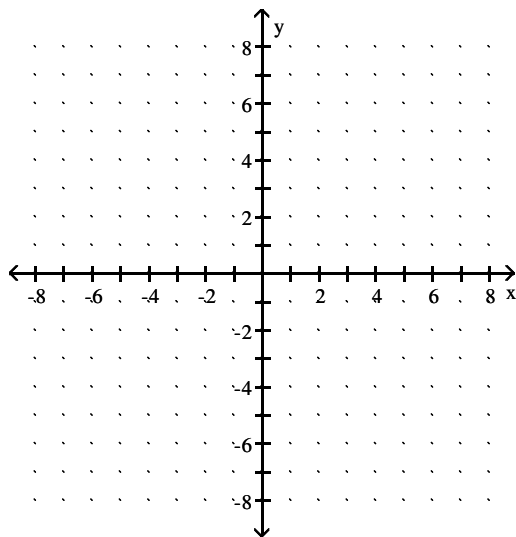

SLOPE

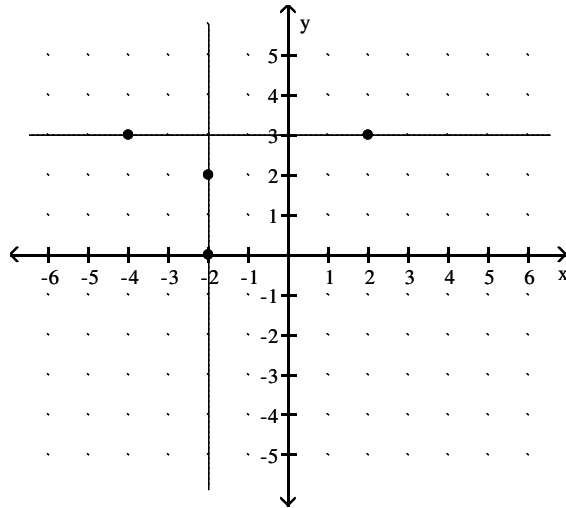
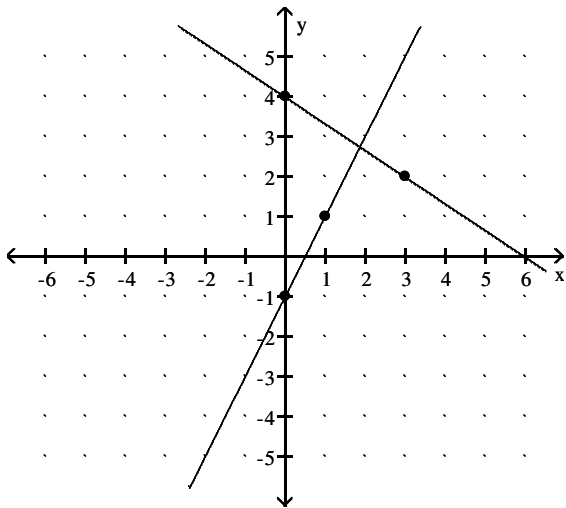

Almost every line has a single numeric value, called the *slope*, that describes its incline. The lowercase letter m is shorthand for *slope*. Slope can be defined in a variety of ways:

"Rise over Run"

"Change in y over Change in x "

"Vertical Change over Horizontal Change"

In fact, the concept of slope makes graphing lines easier. When given the equation of a line, we should first put it in ***Slope-Intercept Form***:

From here, we can just pick off the slope and the y -intercept.

Given: _____

- a. Put in Slope-Intercept Form.

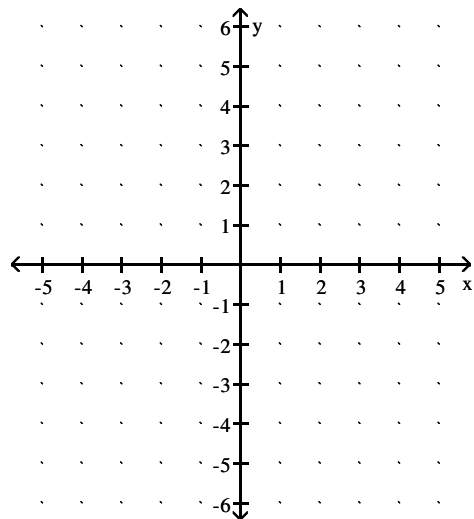

- b. Use this form to graph.

FINDING SLOPE WHEN GIVEN POINTS

The Slope Formula

Given two points (x_1, y_1) and (x_2, y_2) , the slope of the line connecting the points is:

$$m = \frac{y_2 - y_1}{x_2 - x_1}$$

Find the slope of the line that passes through the given points. Then make a quick graph.

$(2, 5)$ and $(-1, 7)$

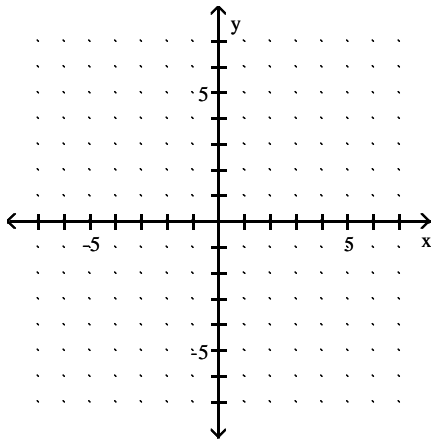

$(-4, 2)$ and $(6, 7)$

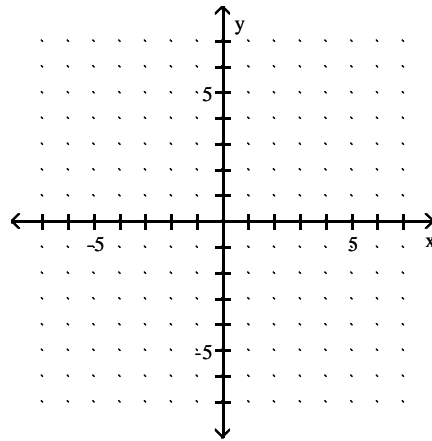

$(-3, 5)$ and $(4, 5)$

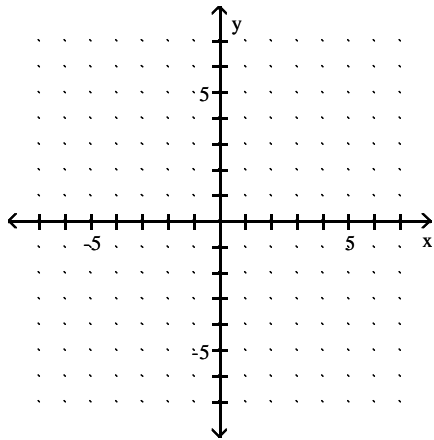

$(-2, 1)$ and $(-2, -3)$

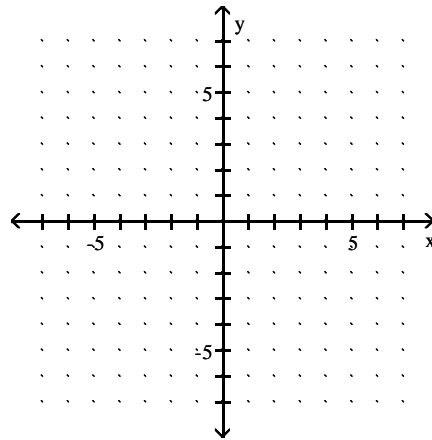

WRITING LINEAR FUNCTIONS

SLOPE-INTERCEPT FORMULA To use this formula you need the **slope, m** , of the line and the **y-intercept, b** . If you are not given these two pieces of information, FIND THEM USING THE GIVEN INFORMATION!

POINT-SLOPE FORMULA To use this formula you need **a point (x_1, y_1)** on the line and the **slope, m** , of the line. If you are not given these two pieces of information, FIND THEM USING THE GIVEN INFORMATION!

HORIZONTAL LINE FORMULA To use this formula you need the **y-intercept, b** . The slope of a horizontal line is zero, so $y = mx + b$ simply becomes $y = 0(x) + b$ which is just:

A line has a slope of -3 and crosses the y-axis at the point $(0, -4)$. Write the equation of the line.

Write the equation of a line that passes through $(-1, 6)$ and has a slope of -2 .

Write the equation of the line that passes through $(4, 0)$ and $(-4, -5)$.

Write the equation of a horizontal line that passes through $(-4, 2)$.

PARALLEL AND PERPENDICULAR LINES

If you are told that the lines are *parallel*, then their slopes are _____.

If you are told that the lines are *perpendicular*, then their slopes are _____.

Write the equation of a line that is **parallel** to the line $2x - y = 6$ and passes through the point $(3, -1)$.

Write the equation of a line that passes through the origin and is **perpendicular** to the line $x + 4y = 5$.

TAKE HOME PROBLEMS

Write the equation of the line that passes through $(0, -5)$ and $(2, 4)$.

Write the equation of the line that passes through $(3, 8)$ and $(7, 2)$.

Write the equation of a line with x -intercept 5 and y -intercept -4 .